

PARÇA KODU PART CODE	PARÇA ADI PART NAME	s ÖLÇÜSÜ (KALINLIK) s MEASURE (THICKNESS)	Malzeme Material	Kaplama / Coating		
				SN	AG	Ni
TE 2301 DP	MİKRO ERKEK FİŞ 2.8 =DP=	-----	(CuZn30) Pirinç / Brass	-	-	-
TE 2301 RP	MİKRO ERKEK FİŞ 2.8 =RP=	-----	(CuZn30) Pirinç / Brass	-	-	-
TE 2301 RPK	MİKRO ERKEK FİŞ 2.8 =RPK=	-----	(CuZn30) Pirinç / Brass	+	-	-

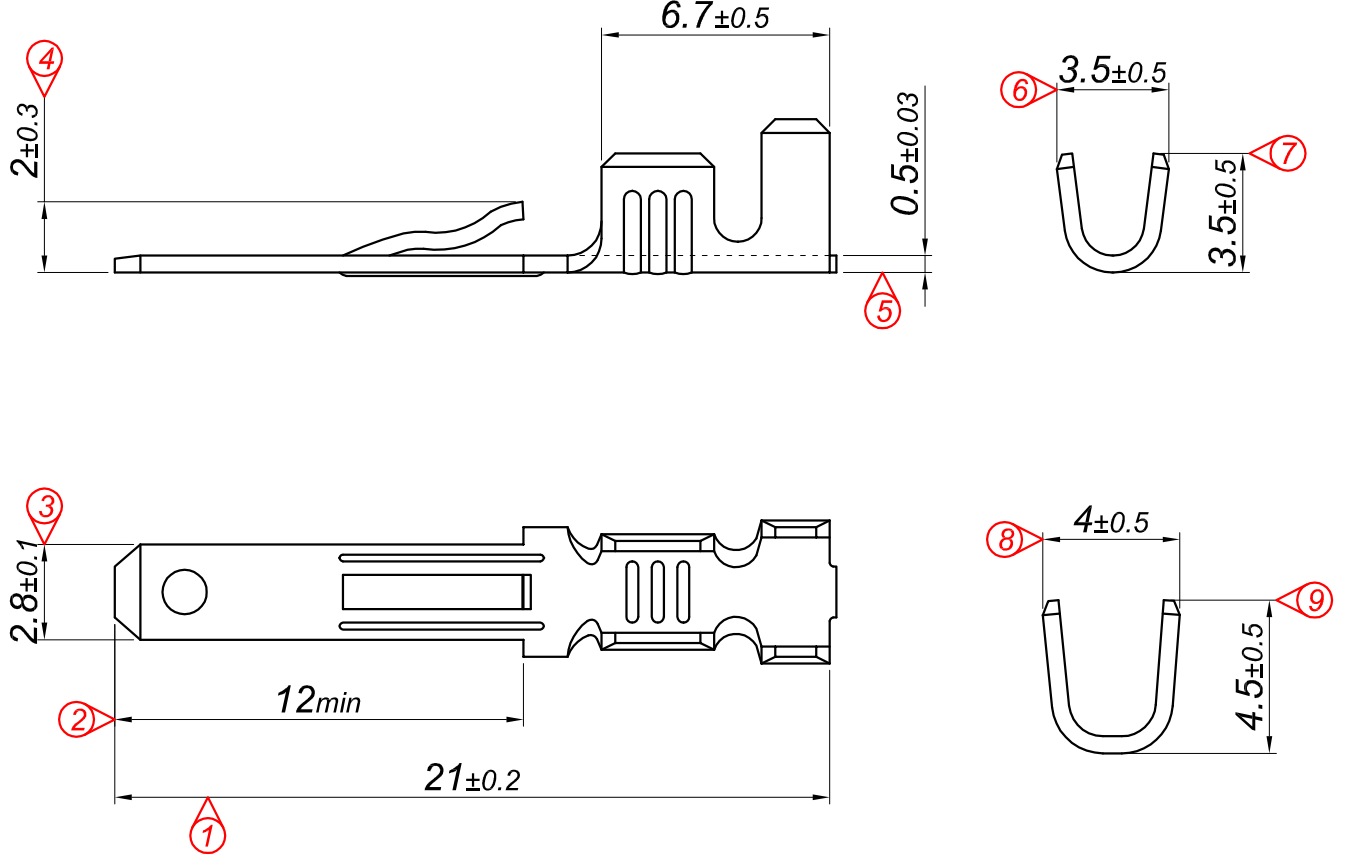

Perspektif  
Perspective

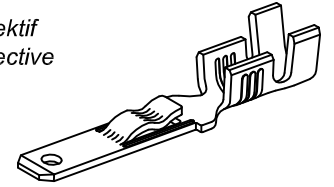

Kalıp çıkış yönü  
Mold output direction

Makara açılım yönü  
Reel opening direction

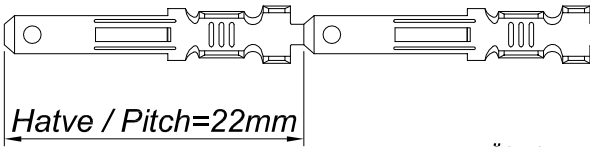

Ölçek  
Scale : 2 / 1

Kablo Kesiti

Wire Section : 0.25 - 1 mm<sup>2</sup>

Resim üzerinden ölçü almayınız  
do not measure on drawing

Tarih / Date	14.11.2012	İmza / Signature	Ölçek / Scale			
Çizen / Desing	M.Yağcı		5 / 1			
Onay / Approval	S.Gölcük		No		Değişiklik / Revision	Tarih/Date
	Parça Adı: Part Name	MİKRO ERKEK FİŞ 2.8		Parça Kodu: Part Code	TE 2301	